

Specialist supplier of:-

- Power Instrumentation, LCR analysis
- Gain-Phase / waveform analysis
- Shunts, CT's, Clamp-on CT's, VT's

Using the GP102 to test Telecom ADSL, DSL and HDSL transformers

Measuring insertion loss

Insertion loss measures the power lost in the transformer. Typically insertion loss is a small number like -0.2dB

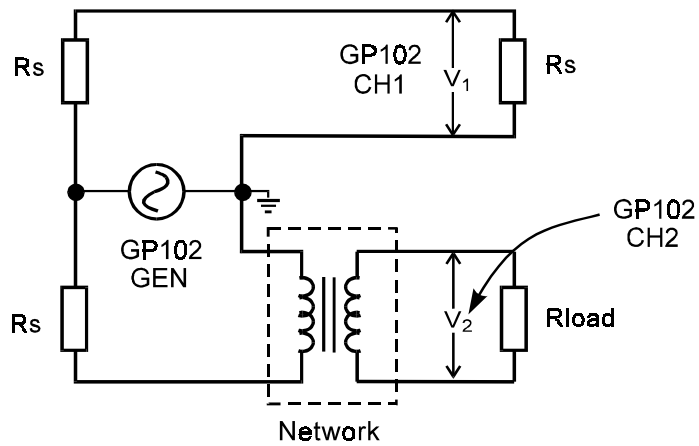

Measuring return loss

Return loss measures the reflected power from the transformer. Typically return loss is a big number like -30.0dB

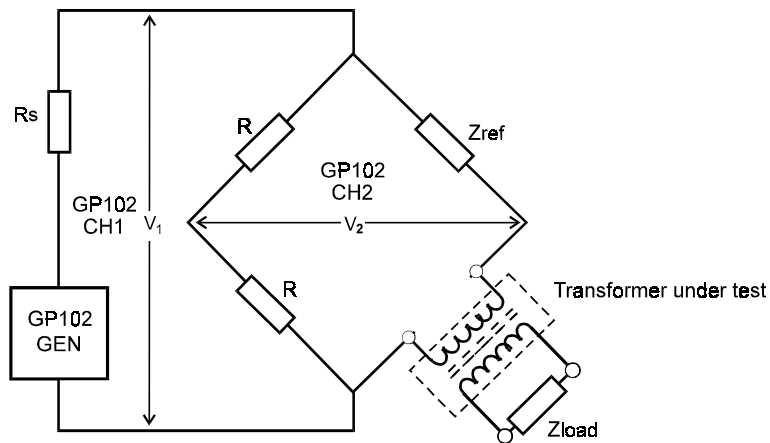

Measuring longitudinal balance/common mode rejection

Longitudinal balance measures the common mode rejection of a transformer. Typically longitudinal balance is a big value like -65.0dB. Ideally with the transformer input virtually shorted, there should be little or no output on the secondary.

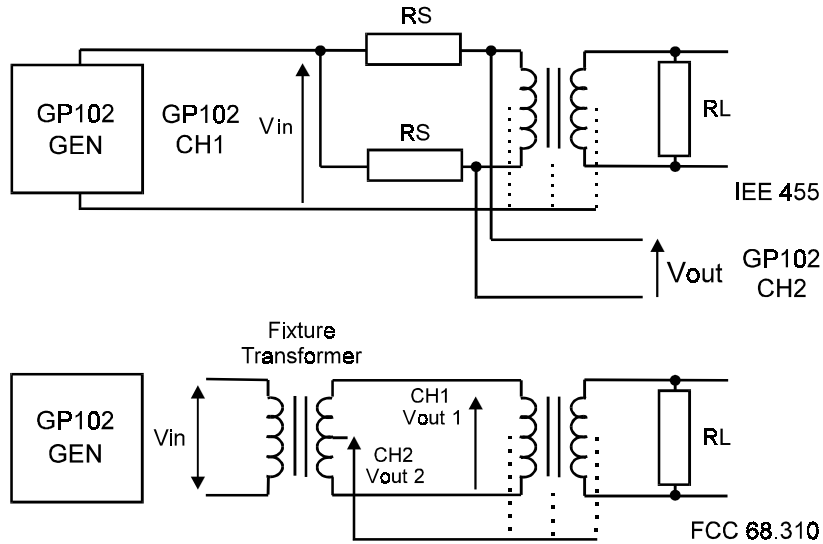

Measuring THD (total harmonic distortion)

In addition to inductance, THD (total harmonic distortion) is useful to determine repeatability of core materials. The transformer is designed to operate in the linear part of the BH curve. Typically THD is calculated from harmonics 2 and 3 and expressed in dB. A very low distortion signal source must be used, typically Black Star LDO100 (0,003% THD = -90dB), the GP102 can measure to a maximum of -75dB.

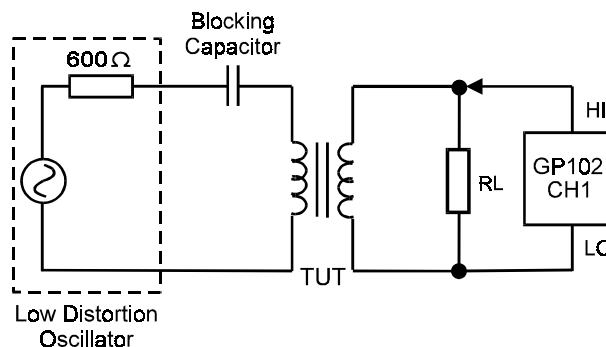

Why the GP102 makes these transformer measurements

The GP102 Gain Phase / Complex Impedance Analyser can make a variety of transformer related measurements using its impedance analysis capability

Inductance L	Checks core material, correct number of turns used.
Quality factor Q	Ratio of X_L / R . Higher Q means the inductance is considered more pure or more inductive
Leakage inductance	Correct position of the windings with respect to the core, where applicable checks for the correct air gap
Inductance match	Used when matching the inductance of 2 or more winding.
Turns ratio (voltage)	Checks the windings have the correct number of turns and turns ratio using the vectorial voltage method
Turns ratio (Inductance)	Ensures windings have the correct number of turns by measuring the ratio of 2 winding inductances
Winding polarity / phasing	Checks for the correct winding polarity or direction, also checks for correct winding start/stop connections
Dc R & winding continuity	Checks winding resistance / therefore wire diameter, over tension during winding etc. Often used at the beginning of a test sequence to ensure good measurement connection is made
Inter winding phase angle	Measures the actual phase angle between 2 or more windings
Impedance test	Measurement of impedance Z (V/A) of wound components, specified at a particular frequency.
Insertion loss	Measures power loss within the transformer. Mainly telecomms
Return loss	Measures power returned/reflected from the transformer. Mainly telecomms
Frequency response	Checks frequency bandwidth of a transformer using either a frequency sweep or spot point tests
Longitudinal balance	Checks common mode rejection ratio of a transformer – Mainly telecomms
Inter winding capacitance	Checks for the capacitance value between windings
Inter winding capacitance match	Ensure capacitance matching between 3 or more windings
Distortion THD	Used to ensure that levels of harmonic distortion caused by a transformer (usually telecomms) meet the required specifications. Also reflects integrity of core materials used
Magnetising current / watts loss	Used mainly in power line transformers to ensure that correct core materials and winding constructions have been used